

ENTRY KIT FOR THE NINETEENTH ANNUAL RACE



October 15-18, 2008

127 Nautical Miles
from Baltimore, Maryland,
to Portsmouth, Virginia

Racing to Save the Bay

MARYLAND

Sunday, October 12

1300 Dinghy Race—A FUNdraiser to benefit the Great Chesapeake Bay Schooner Race.

Tuesday, October 14

Special Event TBA

Wednesday, October 15

- 0900 Education Program—Selected schooners host students for a hands-on learning experience.
- 1200 All schooners docked in Fells Point.
- 1400 All Hands Briefing aboard the Norfolk Rebel.
- 1600 Schooners undock & rendezvous for Parade of Sail.
- 1700 Parade of Sail through the Inner Harbor & Fells Point.
- 1930 All Hands Party in Fells Point.
- 2200 Sailors' Evening dockside.

Thursday, October 16

- 0800 Mandatory Skippers' Meeting in the middle of Broadway Square. Immediately following, schooner crews prepare to cast off & proceed to start.

ON THE BAY

Thursday, October 16

- 1300 Race begins just south of the Chesapeake Bay Bridge near Annapolis.
Finish line is an East-West line at Thimble Shoal Light for classes A & AA. Classes B & C finish at Windmill Point & proceed to docking in Portsmouth, VA.

VIRGINIA

Saturday, October 18

- 0900 Education Program—Selected schooners host students for a hands-on learning experience.
- 1000 Time limit—All racers report finish times to Race Committee.
- 1300 Oyster & Pig Roast & Awards Ceremony.
- 2100 Sailors' Evening dockside.

Sunday, October 19

- 0800 Schooner Captains' Debriefing followed by breakfast for captains & crew at Roger Brown's. Schooners depart as desired.

If you would like to participate in our education program, or if you can host a member of the press, a volunteer or a VIP during the race, please call the race line, 757-480-4402.

PLEASE ENTER PROMPTLY

as we will only accept paid entries up to 3,000 feet total docking length.

First-come, first-entered, so we urge you to complete & return your entry forms promptly. Entries will be put on a waiting list after the limit of 3,000 feet of docking length is reached. We understand that your plans may not be firm until closer to the starting date. *If you plan to join us, please ESTIMATE data & submit your entry forms now.* There is no penalty for making changes later.

FREQUENTLY ASKED QUESTIONS

What is the purpose of this event? The mission of the Great Chesapeake Bay Schooner Race is to promote public awareness of the Chesapeake Bay's maritime heritage & to encourage the preservation & improvement of the Chesapeake's natural resources.

Who benefits from this year's race? Proceeds from the Great Chesapeake Bay Schooner Race 2008 will support children's education programs at the Chesapeake Bay Foundation & other charitable organizations.

How big is the event? Last year there were 38 entries. Over 150 schooners have participated over the last eighteen years.

How did it start? The first annual race was in 1990, with seven entries. Every one has returned; two, *Patricia Divine* & *Norfolk Rebel*, have raced every year. Forty schooners have raced five or more times.

Who can participate? Entry is open to all schooner-rigged vessels. The Race Committee reserves the right to reject entries for reasons of safety.

Can I talk with a skipper who has raced in the past? Just ask us for contact information.

I may not race until next year; how can I check it out? Owners & captains of non-participating schooners are invited to contact us to arrange admission to land events.

What if I can't get away for the whole event? If your schedule will not permit participation in all events, we still want you to come. Contact us to make arrangements.

Can my friend's classic wooden ketch sail in company? Sorry—only schooners. No spectator fleet.

What's the deadline for entries? The cut-off for the 3,000-foot fleet limit will be determined on a first-paid, first-entered basis. Captains who submit an entry package immediately have the best chance of inclusion. The date & time when you send your entry will be used to resolve any ties. Only complete entries will be considered. If your entry is incomplete, the Race Office will call you. Schooners planning to join only the Baltimore festivities do not count toward the 3,000-foot limit.

What happens if I miss the cut-off date? A waiting list will be

maintained once the limit is reached. We will contact wait-listed vessels.

After I have entered, do I just show up at the start? Please refer to the events schedule for activities on Wednesday, October 15. The mandatory Skippers' Meeting is at 0800 Thursday, October 16—schooners not represented shall be disqualified. Captains unable to attend in person must arrange official representation & notify the Race Committee. Also, we request that you arrange for your Baltimore arrival with the Baltimore Race Dock master.

Do I have to participate in the Parade of Sail? Parade participation is optional, but encouraged, as it helps develop public awareness of the event, is good for race publicity & helps generate future financial support. If you have room on board for a guest or two, please consider embarking some race sponsors or volunteers.

Can I invite my family & friends to the land events? Unfortunately, the sheer numbers of crew members & sponsors make this impossible.

Why do I pay extra for my paying passengers? Race expenses grow in direct proportion to the number of people on board participating schooners. We expect commercial vessels would pass this cost on to their customers.

Why do you request a donation from participants? The race is a grassroots event: the same volunteers who donate work, donate money. Where possible, we hope that schooners, as primary beneficiaries, would also be willing to share the cost. Many captains, even those not participating, enjoy making a contribution to assure the continued success of this event & support its mission. We want the event to be affordable for all schooners; donations are strictly voluntary. Net proceeds from the race are donated to the Chesapeake Bay Foundation & other charities. Donations to the race are tax-deductible under 501(c)3 & qualify for employer matches. We list each donation under the boat's name on our promotional materials unless you instruct otherwise.

When do I have to be in Baltimore? All schooners are expected to dock in Fells Point no later than 1200 Wednesday, October 15. You are welcome to arrive as early as you wish; docking will be arranged.

SAFETY STATEMENT

This is meant to be a fun race; however, the safety of the vessel & her crew is the sole & inescapable responsibility of the captain, who must ensure that the vessel is sound, seaworthy, & manned by experienced crew who are physically fit. The captain must further ensure that all equipment is properly maintained & stowed, & that the crew knows its location & proper usage. It is also the sole & exclusive responsibility of the captain to decide whether or not to start or continue in any race. Vessels will be disqualified for unsafe operation or failure to have formal representation at the Skippers' Meeting on Thursday morning. *The race involves sailing at night in an area busy with commercial traffic. All participating vessels must fly radar reflectors, maintain a radio watch, & keep a good lookout at all times. Vessels unfamiliar with night sailing on the Chesapeake are encouraged to seek local knowledge before entering the event.*

(Continued from page 2)

What if my plans change after I send the entry forms? Please contact us at 757-480-4402 or race@schoonerrace.org.

Is my entry fee refundable? Your entry fee & donations are a major part of our contributions to our selected charities. The fee is not refundable.

How do I contact the Race Committee? *Before & after* the race, get in touch with us at 757-480-4402 or race@schoonerrace.org for matters having to do with your entry. For anything related to special needs in Baltimore (crew changes, hotels, etc.), please contact Paul Schaub, the Maryland Race Chair, *before* the race at 410-245-4357 or Maryland@schoonerrace.org. During race week, all volunteers are at the race. You may contact the Race Chairs *during race week* as follows:

Tuesday & Wednesday: Paul Schaub at 410-245-4357

Friday through Sunday: Susan Cocke at 757-650-3052

Where do I dock in Baltimore? Arrange for docking by notifying our Baltimore Dock master, Paul Brabazon, of your ETA in Fells Point as far in advance as possible. (Alert us if your plans change.) We will help you arrange transportation, provisioning, ice, etc. Early arrivals are welcome & can receive free docking beginning on Friday, October 10. Hail "Schooner Race Dock Master" on VHF 16 as you enter the harbor. You may also contact Paul Brabazon at 484-553-9932 or pbrabazon@yahoo.com; or Paul Schaub at 410-245-4357.

What do I do when I get to Fells Point? Please fuel your vessel & pump your holding tank before docking. We encourage all participants to take a turn around the Inner Harbor under sail before they tie up to promote the race to the public.

How can I receive mail, packages & faxes during race week? Contact Paul Schaub at 410-245-4357 regarding deliveries before & including October 15. Use the Portsmouth address for deliveries after October 15. Please notify us if you are expecting something so we will be looking for it, & specify the schooner's name on each item.

May I open to the public for tours? Yes, in both ports. Send us a press kit. If you sell souvenirs, keep this activity aboard the vessel, please.

What do I put on my Float Plan? Expect to arrive in Portsmouth between Friday morning & Saturday morning, depending on the weather & your speed. Make sure your family knows how to communicate with us in event of personal emergencies.

Do I have to complete the Entry Form if everything is the same as last year? *Yes!*

Do I have to complete the Handicapping Data Form? *Yes!* Even if you have raced with us before & measurements, prop, sail inventory, etc. remain unchanged, we need you to send your information. If rated under the 1974 Off Soundings Club Rating Rule for another event, please submit that rating along with your measurements. Please measure your vessel & mail, fax or email this data to us as early as you can. We strongly advise you to measure your boat, not her plans.

Must I order your shirts? **I don't need any more**

shirts. Yes, they admit you to all festivities.

Why do you want so much information about my schooner? We put a picture & a short write-up about every entry in our souvenir Race Handbook. This year, as was the case last year, every schooner's picture will be featured along with a short biography as an insert in the Annapolis Boat Show issue of *Spinsheet* magazine. We'd like to know how long you've had her, where you have been sailing her, what you know about her history, & anything about her that makes you love her. The more you tell us, & the better her picture, the more you will like the Handbook & *Spinsheet* biography. If possible, please email her picture to race@schoonerrace.org.

Does the race have a web page? Of course! www.schoonerrace.org. Your link is welcome.

What do I tell the cook? We will assist with transportation for provisioning in both ports. Sixteen pound bags of ice will be available in Portsmouth at cost. We feed you on Wednesday night & Saturday afternoon. Other meals on your own. There are great places to eat within an easy walk of our docks.

Who organizes this race? The Great Chesapeake Bay Schooner Race, Inc. is a Virginia nonprofit corporation under 501(c)(3). About 100 volunteers in each port, led by Race Chairs, provide the hard work.

ENTRY CHECKLIST

Part One

- Review Frequently Asked Questions
- Read Safety Statement
- Attach photograph or line drawing or
- Email photograph to race@schoonerrace.org*
- Attach boat history & activities*
- Complete & sign Entry Form

Part Two

- Measure boat for changes
- Complete handicapping data form*

Part Three

- Determine shirt sizes for crew, gifts, etc.
- Complete shirt order form

Part Four

- Compute entry fee & other charges
- Enclose check or credit card info or pay via PayPal

Plus

- Please keep copies of everything
- Note here: Documents submitted
- on _____ via _____.

** Please submit even if on file with race already.*

PLEASE SUBMIT ENTRY FORMS

BY REGULAR MAIL TO:
GCBSR

3001 High Street
Portsmouth, VA 23707

OR BY FAX TO: 410-293-3197

OR EMAIL TO: entry@schoonerrace.org

PART ONE: ENTRY FORM

Schooner name: _____ Former name/s: _____
Sparr length: _____ Home port: _____ Arriving in Baltimore from: _____
Contact person: _____ Mobile phone: _____
Day phone: _____ Evening phone: _____ Fax: _____
Email: _____ Web site: _____
Captain (if different): _____ Owner (if different): _____
Permanent address: _____
Seasonal address & dates: _____
Shore side emergency contact during race week: _____
Day phone: _____ Evening phone: _____ Mobile phone: _____

CREW

Please list tentative crew. You will be asked to submit a final crew list at the Skippers' Meeting on Thursday morning.

crew & officers under 21: _____ # crew & officers 21 or over: _____ Total crew & officers: _____
paying passengers under 21: _____ # paying passengers 21 or over: _____ Total paying passengers: _____
Total persons under 21: _____ Total persons 21 or over: _____ Total persons on board: _____

HOSPITALITY

Docking preference: Starboard side to Port side to No preference *If available:* Electric volts/amps: _____
Open to the public? No Yes, Baltimore on Wednesday Yes, Portsmouth on Saturday Yes, Portsmouth on Sunday
Room for volunteers or sponsors for the Parade of Sail? No Yes If Yes, how many? _____
Any dietary restrictions? No Yes If Yes, please describe: _____

FLOAT PLAN

Day & date of estimated arrival in Baltimore: _____ AM PM
Day & date of estimated departure from Portsmouth: _____ AM PM
If you do not expect to attend race events in both ports, please advise: _____

SAFETY EQUIPMENT

EPIRB VHF GPS SatNav Radar WeatherFax SSB Life raft Dinghy/yawl boat Trysail Storm jib
Other: _____

BOAT DATA

Draft: _____ Beam: _____ Freeboard: _____ Hull material: _____
Designer: _____ Design, type or model name: _____
Builder/rebuilder: _____ Build/rebuild location: _____
Built/rebuilt year: _____ Power: _____ Working sail area (lowers): _____
Photo: None Attached Sent to race@schoonerrace.org Bio/press kit: None Attached Sent to race@schoonerrace.org

HOLD HARMLESS

Please read before signing. I agree to abide by the regulations & sailing instructions for this event, &, by signing below, confirm that I have read the attached Safety Statement & that my vessel conforms in all respects. I hereby agree that neither I nor any of my crew members, cadets or passengers shall hold the Great Chesapeake Bay Schooner Race, Inc., nor any of its personnel responsible for damage, accidents or injuries during the race or related activities; no person shall be aboard my vessel who has not consented to this waiver in his or her behalf. I understand that organizers may transfer to third parties the right to film or tape part or all of the event for eventual license, sale or distribution, & agree that neither organizers nor such third party has any obligation to compensate entrants in any form.

Signed: _____ Title: _____ Date: _____

Check here if you decline permission for us to trade your address with related non-profits (ASTA, ASA, CBF, Mystic). We very seldom share our mailing list.

PART TWO: HANDICAPPING DATA FORM

Schooners will be rated under the 1974 Off Soundings Club Rating Rule. Its basis is the amount of theoretical sail area (lowers) you have room for, not your actual inventory. Owners are reminded that boats as built always differ from their line drawings — we recommend you measure the boat, not her plans. **Even if your handicapping data is on file with us, please complete ALL of this form.**

Schooner name: _____

Completed by: _____ **Date:** _____

Mainsail rig: Marconi Gaff None Unstayed

Number of masts: _____ **Number of propellers:** _____

Prop type: Solid Feather/Fold

blades: _____

Prop size: _____ x

No engine? Describe towed yawl boat (LWL, prop, draft, etc.):

SPECIAL DOCKING NEEDS? Please explain: _____

Note: We may make allowances for excess displacement, oversized props, etc., so if you feel your schooner has not been properly rated or classed, please let the Race Committee know of your concerns. The Race Committee reserves the right to adjust ratings to promote competitive racing.

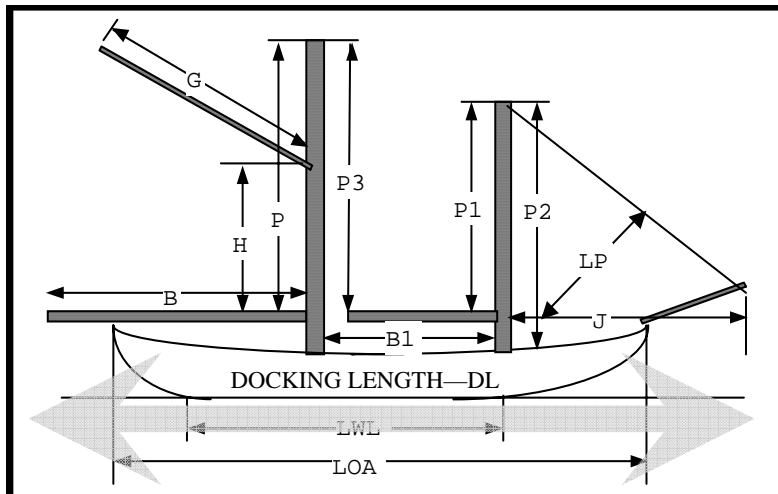

Please state measurements in feet & inches to the nearest whole inch.

FT IN

LOD: Length on deck. (This may be on your documentation as "LOA.")	LOD	
LWL: Waterline length.	LWL	
Beam: Maximum beam.	Beam	
DL: Docking length. (We need to know how much space you will take up!)	DL	
B: Distance from fair extension of aft side of mainmast, sail track or groove to aftermost position to which mainsail clew can be extended, or inner edge of boom black band.	B	
B1: Distance at deck between forward side of mainmast & after side of next mast.	B1	
B2: (3 & 4-masters only) see B1 above for third mast.	B2	
B3: (4-masters only) see B1 above for fourth mast.	B3	
J: Distance from forward side of mast at deck to intersection of foremast stay on which foremost headsail is normally carried, with top of bowsprit, if used, or top of rail including cap.	J	
P: Distance from fair extension of top of boom track when touching lowest point of gooseneck, or from top of black band, if used, to top of main halyard sheave or to underside of masthead black band, if used & appropriate halyard marking is included.	P	
P2: Distance from intersection of forward face of mast with centerline of main deck to intersection of forward face of mast with centerline of headstay or strop carrying highest headsail.	P2	
P1: Perpendicular measured along after side of mast from top of highest halyard block used for sails aft of mast to upper side of boom when at lowest position of gooseneck.	P1	
P4: (3 & 4-masters only) see P1 above for third mast.	P4	
P6: (4-masters only) see P1 above for fourth mast.	P6	
P3: Perpendicular measured along forward side of mast, from top of highest halyard block used for sails forward of mast, to upper side of boom when resting parallel to deck against the lowest point of gooseneck. If no fisherman staysail carried, measure from point opposite highest halyard block on after side of mast.	P3	
P5: (3 & 4-masters only) see P3 above for third mast.	P5	
P7: (4-masters only) see P3 above for fourth mast.	P7	
G: Extreme length of gaff, when lying on top of boom, to the mast proper.	G	
H: Perpendicular measurement along after side of mast, from throat cringle of sail to upper side of boom.	H	
LP: Shortest distance between extreme after end of clew cringle & forward side of luff rope.	LP	

PART THREE: SHIRT ORDER FORM

Schooner name: _____

Contact person: _____ Phone: _____

This year you will receive top-quality, heavy-weight, 100% cotton, long-sleeved, crew-necked tees, delivered to you in Baltimore. Prices include tax. Only sizes listed are available. They make great souvenirs or gifts. Additional race merchandise, including short-sleeved shirts, sweatshirts, hats, etc., will be available at the race.

Official race shirts serve as your admission ticket to all events, so order at least as many shirts as you have persons on board. *The first two shirts are free.* For orders of 12 or more shirts, we will print your schooner's name on them for free.

"Quantity Ordered" should be the same in both outlined boxes:

Quantity of Each Size	Qty	@ Price	= Total
Small:			
Medium:	2 for Captain & Mate:	2	Free \$ 0
Large:	# for on-board crew:	\$18	
Extra large:	# additional shirts:	\$20	
XX large:	Quantity ordered: 		
TOTAL quantity ordered: 		TOTAL shirt fees:	\$

PART FOUR: PAYMENT

Tax-deductible entry fee @ \$1 per foot of your LOA, maximum \$100:.....\$ _____

Surcharge for paying passengers: # _____ @ \$20 per passenger:\$ _____

Total shirt fees:\$ _____

Optional tax-deductible donation* to support the race:.....\$ _____

Total amount remitted:.....\$ _____

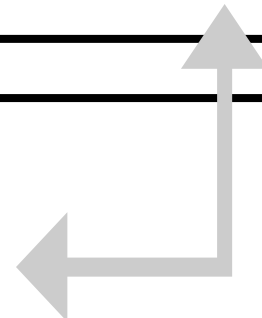

If forms will be mailed & you prefer to pay by check, money order or traveler's check, these should be made payable to GCBSR.

If forms will be faxed or sent via email, please complete MasterCard or Visa information below or make payment with a credit card via PayPal on the Web site at www.schoonerrace.org.

Visa MasterCard Card # _____

Exp. ____/____ Print name on card: _____

Billing address for card: _____

**Donations will be listed under your schooner's name on promotional materials unless you specify otherwise:*
